



Jack Wechat



Jack Facebook



Large needle gauge heavy duty computerized lockstitch machine



JK-2002G

2020.6

JACK SEWING MACHINE CO.,LTD.

No.1008,DonghaiAvenueEast,jiaojiangDistrict,TaizhouCity,Zhejiang
TEL: 0086-576-88177782 88177767
FAX: 0086-576-88177787

E-mail: sales@chinajack.com
www.chinajack.com

JK-2002G

Item: Large needle gauge heavy duty computerized lockstitch machine
 Feature: strong feeding, large needle gauge, fast speed



This product is suitable for sewing tents, automotive products, home textiles, woolen sweaters, slippers, non-woven bags, hats and other sewn products, with large needle gauge, fast speed and strong feeding ability.



woolen sweaters



disposable slippers



non-woven bags



hats

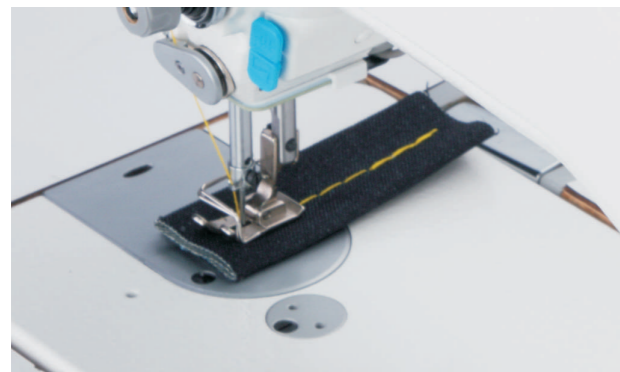

1 Stronger thickness feeding ability, high efficiency

750W high power motor, has stronger thickness feeding ability, better thread take-up effect and more beautiful stitch.



2 Full function panel, easy to operate

Complete functions, adapt to different process requirements, can set fixed needle sewing, multi-stage sewing, piece count fast function and other sewing modes.



3 Large needle gauge, both for thin and thick material

The max needle gauge achieves to 12mm, according to the requirements of sewing products, the needle gauge is set randomly.

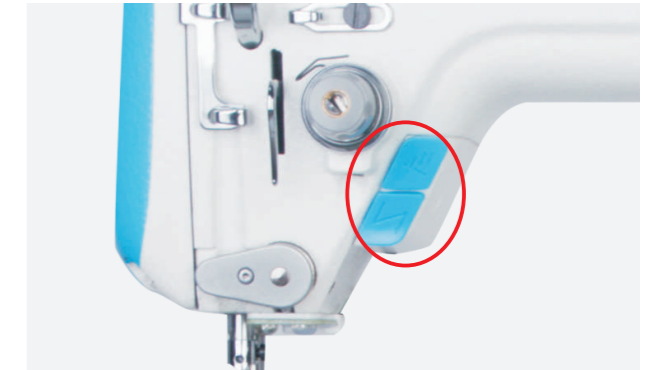

4 Intelligent dual switch

Multi level brightness LED light can adapt to sewing in different fabric environments, and have function buttons of reinforce sewing and needle filling, easy to operate.

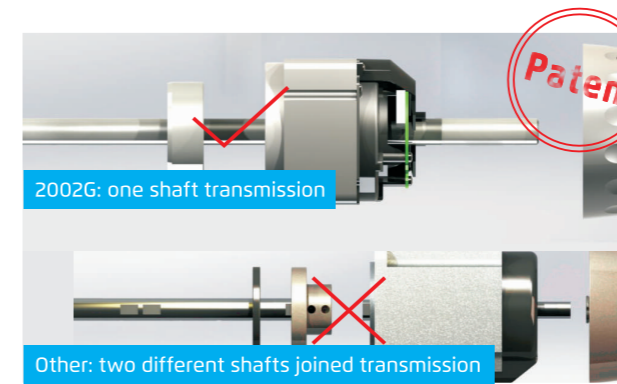

5 Single shaft design, Stable and light

More stable transmission, longer service life, lower torque and vibration.



6 Electric and pneumatic presser foot lifter (optional)

According to the needs of customers, dealers can configure electric or pneumatic presser foot lifter to reduce the labor intensity of operators and improve efficiency.

Specification

Model	Application	Needle	Thread number	Max needle gauge	Press footer height	Max speed (S.p.m)	Auto trimmer	Auto back stitch	Auto tension	Auto foot lifter	Volume (mm)	Weight (kg)
JK-2002GHC-3Z	woolen sweaters disposable slippers non-woven bags hats	DPx17 22#	2	8	by hand is 7mm/ by knee is 16mm	3000	√	√	√		725x285x580	37/45
JK-2002GHC-4Z	woolen sweaters disposable slippers non-woven bags hats	DPx17 22#	2	8	by hand is 7mm/ by knee is 16mm	3000	√	√	√	√	725x345x580	39/48
JK-2002GHC-3Z-12	woolen sweaters disposable slippers non-woven bags hats	DPx17 22#	2	12	by hand is 7mm/ by knee is 16mm	2800	√	√	√		725x285x580	37/45
JK-2002GHC-4Z-12	woolen sweaters disposable slippers non-woven bags hats	DPx17 22#	2	12	by hand is 7mm/ by knee is 16mm	2800	√	√	√	√	725x345x580	39/48